



30" X 30" ADA CASTING

Created: June 12, 2017

Revised: February 21, 2018

Scale: N.T.S.

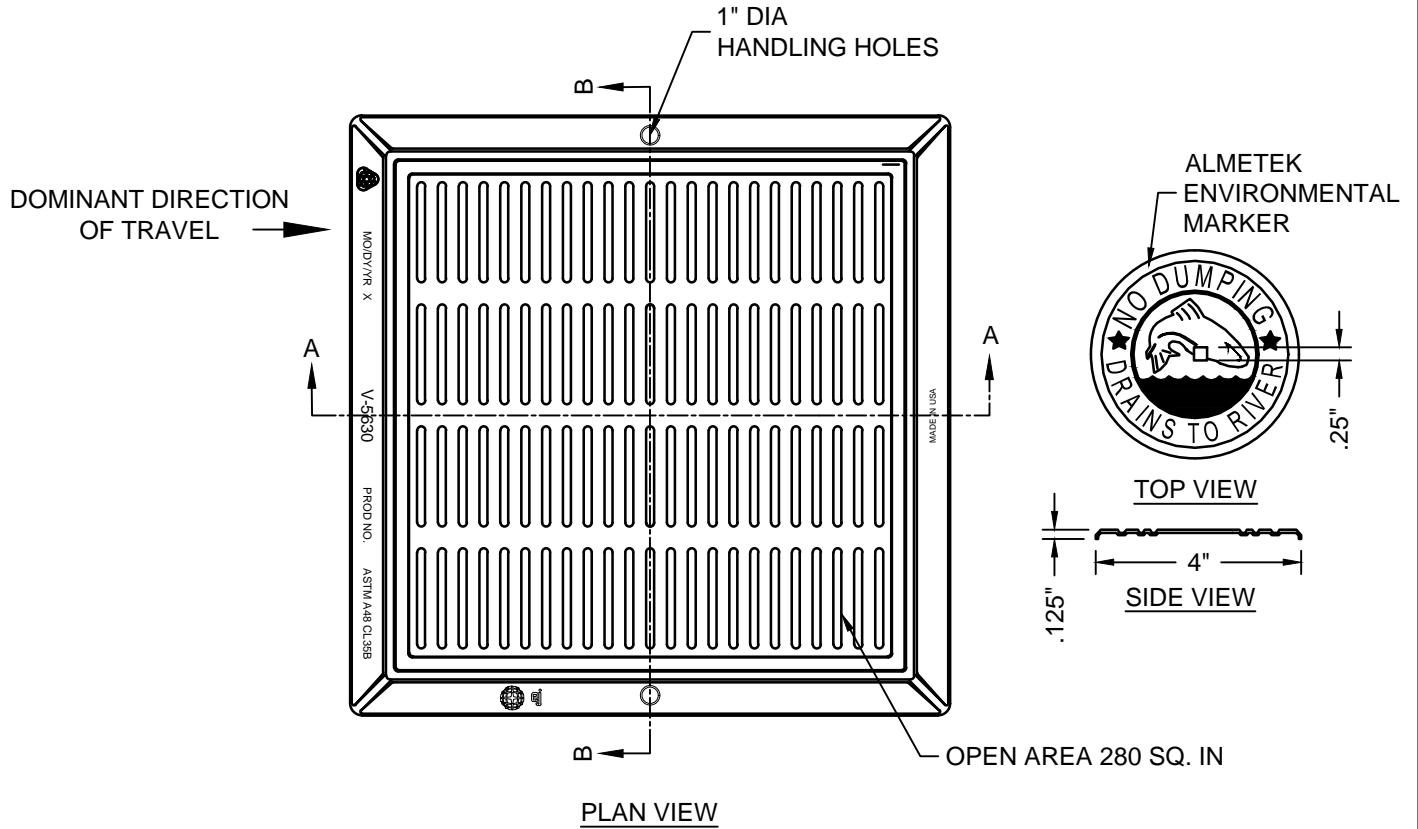

PLAN VIEW

FRAME AND GRATE
E. JORDAN V5630 FRAME W/5630-80 ADA GRATE
W/ ALMETEK ENVIRONMENTAL MARKER

- NOTES:**
1. DESIGN LOAD: HEAVY DUTY
 2. ASTM A48 CLASS 35B
 3. USE WITH 30"X30" INLET STRUCTURE

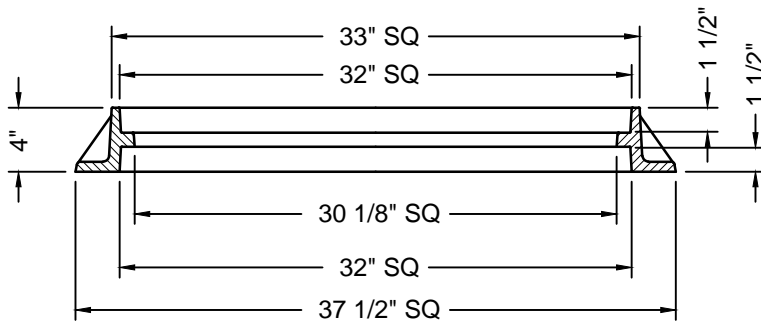

FRAME SECTION

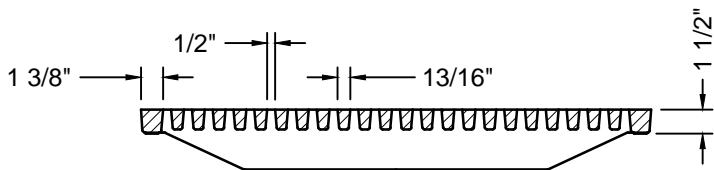

GRATE SECTION A-A

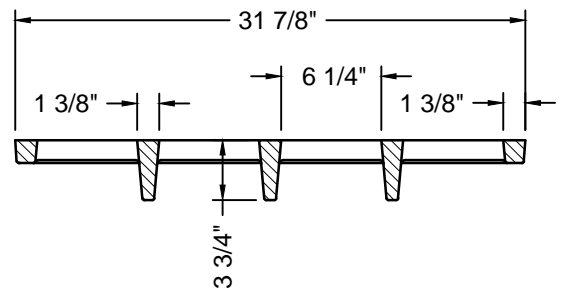

GRATE SECTION B-B