



PIPE CONNECTION TO MANHOLE - COMPRESSION

Created: January 1, 2002

Revised: October 21, 2015

Scale: N.T.S.

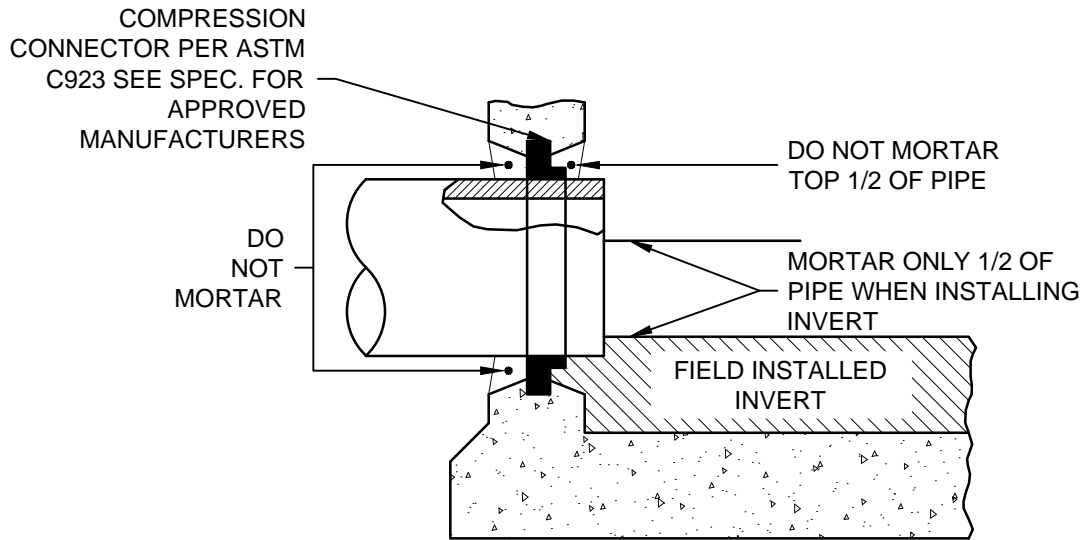

COMPRESSION
TYPE CAST IN
PLACE

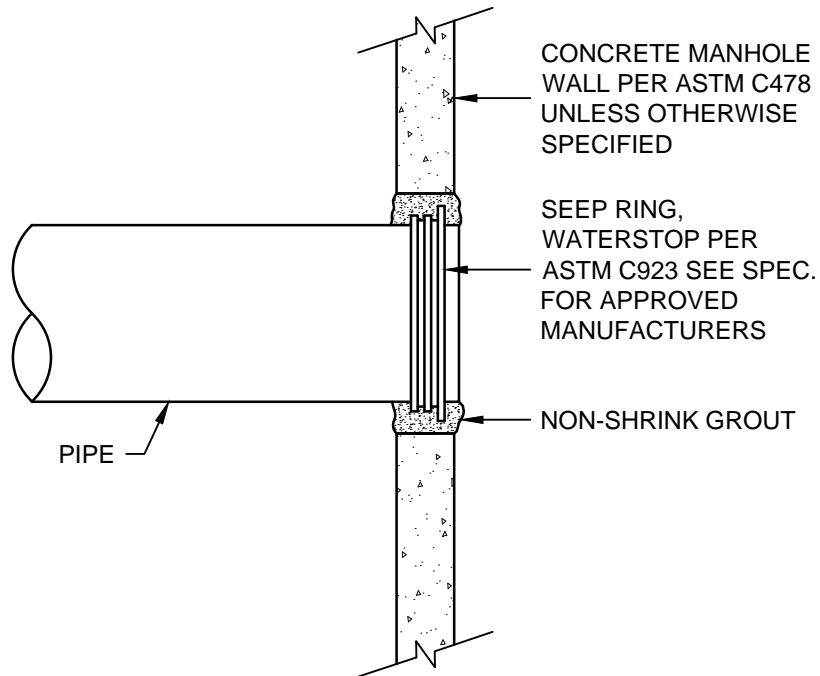

COMPRESSION
TYPE GROUT IN
PLACE

NOTES:

1. WHEN INSTALLING PIPE STUBS FOR FUTURE PIPELINE, INSTALLATION OF ALL STUBS SHOULD BE PROPERLY RETAINED TO PREVENT ANY MOVEMENT.
2. TYPICAL APPLICATION IS FOR PIPES LARGER THAN 36".