



SANITARY CASTING ADJUSTMENT

Created: January 1, 2002

Revised: August 16, 2016

Scale: N.T.S.

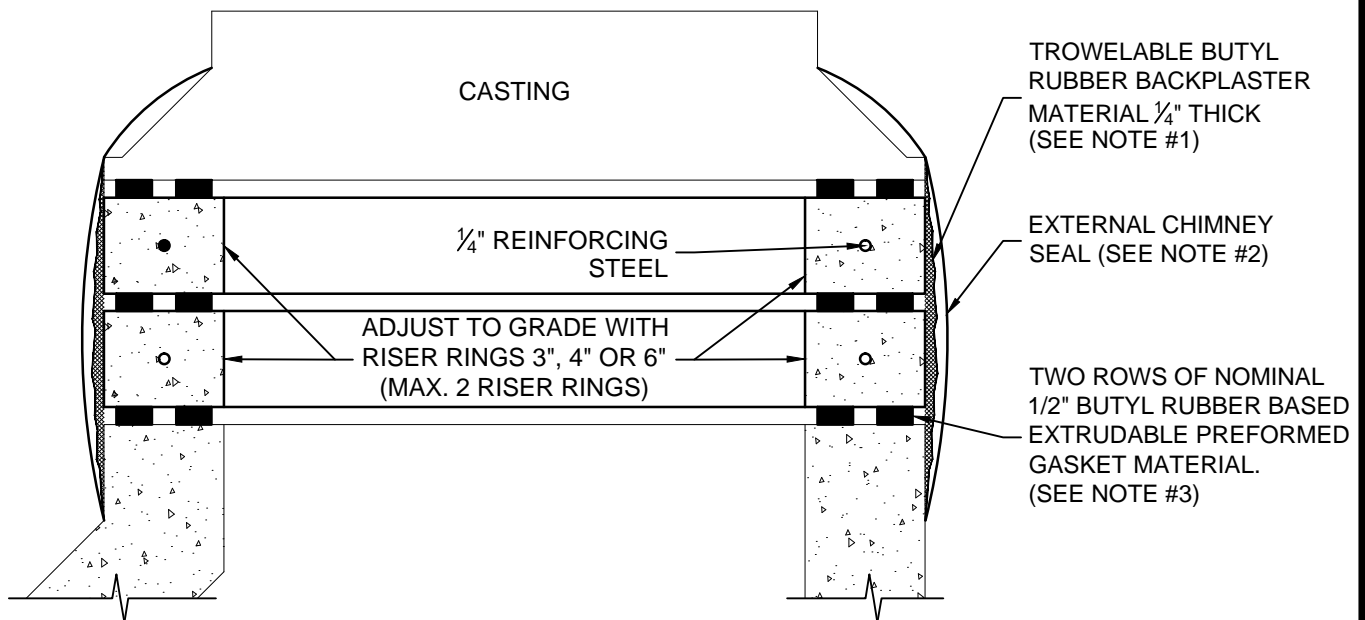
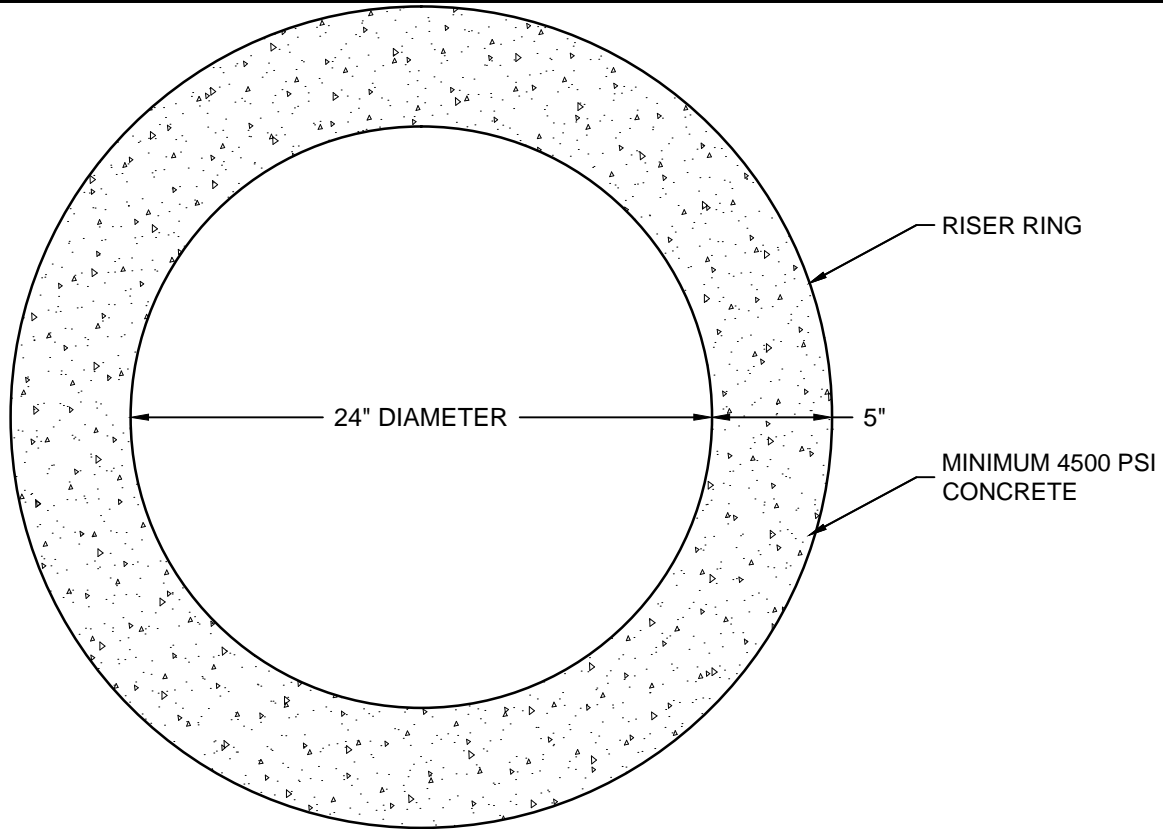

NOTES:

1. APPLY TROWELABLE BUTYL RUBBER BACKPLASTER MATERIAL 1/4" THICK (WHEN DRY) OVER RISER RINGS FROM 6" ABOVE TO 6" BELOW RISER RING JOINTS. USE TROWELABLE EZ-STICK #3, AS MANUFACTURED BY PRESS-SEAL GASKET CORP.
2. EXTERNAL CHIMNEY SEAL SHALL CONSIST OF A HEAT-SHRINKING WRAP-AROUND SLEEVE (USE WRAPIDSEAL AS MANUFACTURED BY CANUSA) OR EXTERNAL CHIMNEY SEAL (AS MANUFACTURED BY CRETEX).
3. USE RU 106 RUB'RNEK LTM AS MANUFACTURED BY HENRY CO., KENT-SEAL NO. 2 AS MANUFACTURED BY HAMILTON-KENT OR EZ-STICK BUTYL-RUBBER-BASED PREFORMED FLEXIBLE SEALANT AS MANUFACTURED BY PRESS-SEAL.