



STRUCTURE CONFLICT

Created: November 8, 2011

Revised: January 6, 2017

Scale: N.T.S.

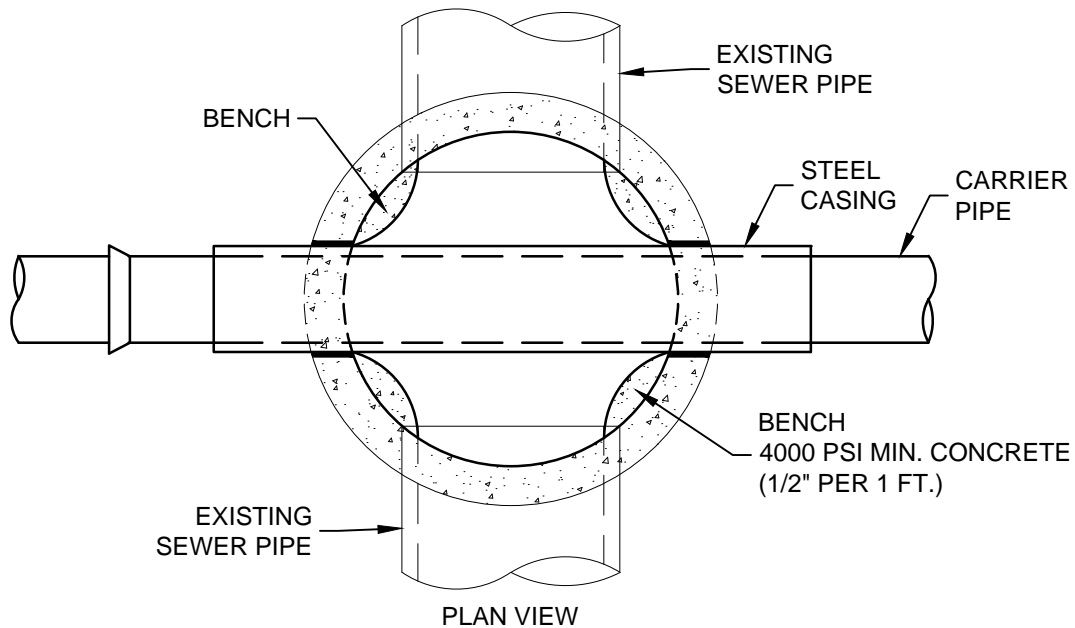
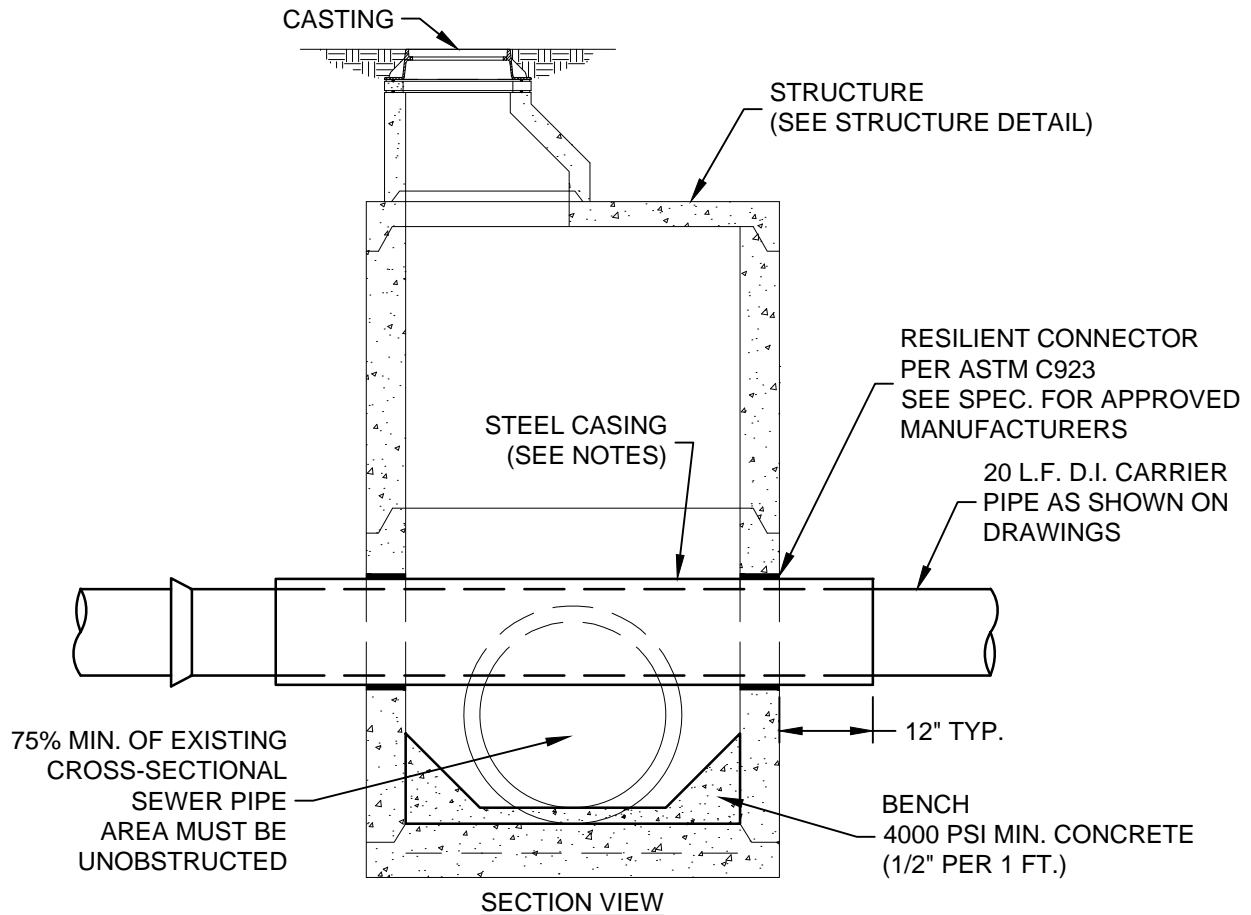

NOTES:

1. STEEL CASING REQUIRED ON A CASE BY CASE BASIS PER CITY UTILITIES PROJECT ENGINEER.
2. DUCTILE IRON PIPE SHALL BE USED FOR CROSSING PIPE IF CASING IS NOT USED.
3. CASING SPACERS SHALL BE USED WITH STEEL CASING. REFER TO CASING SPACERS TYPICAL DETAIL.
4. IT IS PREFERRED TO HAVE THE SANITARY SEWER PIPE RUN THROUGH THE THE MANHOLE (AS CARRIER PIPE) WHEN POSSIBLE.
5. DETAIL SHALL NOT BE USED FOR POTABLE WATER.