



# 1500 GALLON PRECAST GREASE INTERCEPTOR

Created: September 6, 2011

Revised: March 24, 2021

Scale: N.T.S.

Approved: May 19, 2015

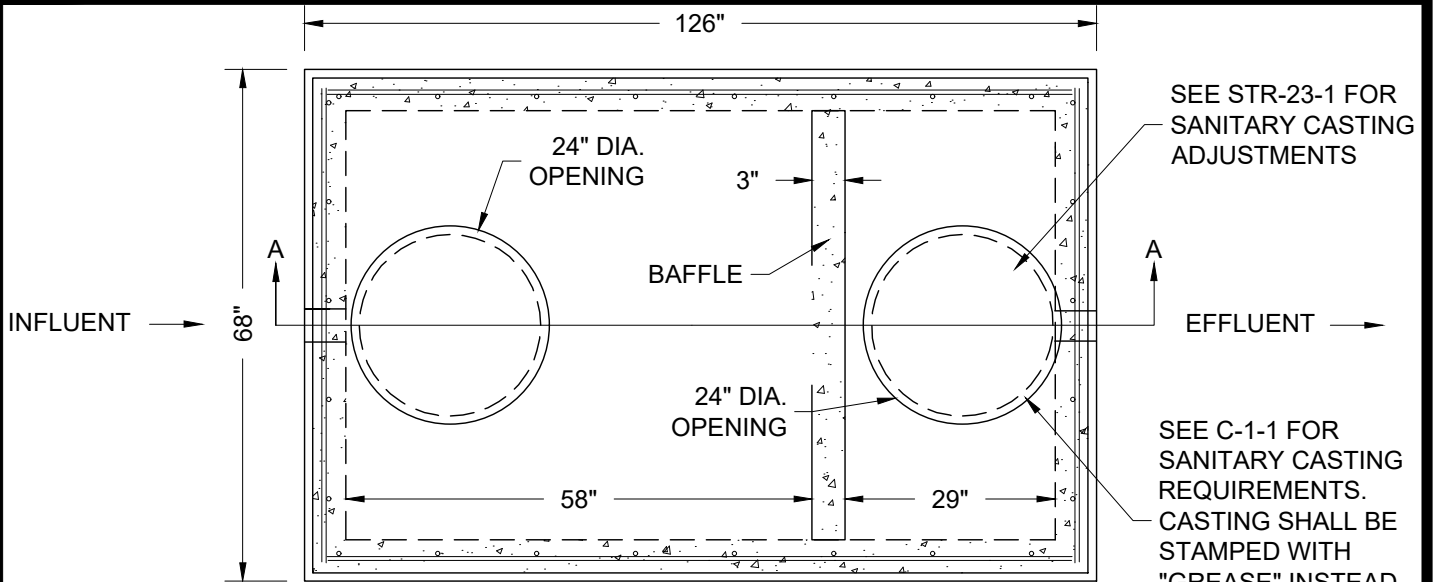

TANK WEIGHT = 15,000#

TOP VIEW

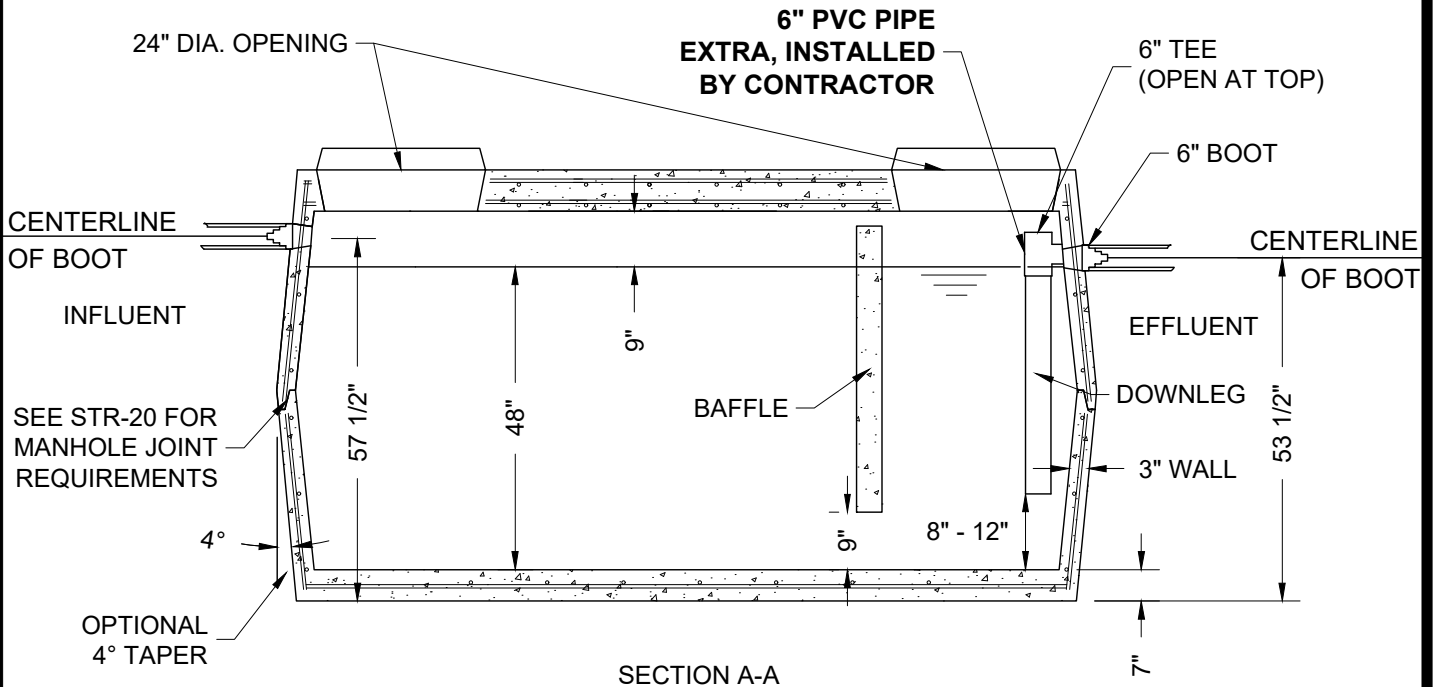

**NOTES:**

1. MINIMUM 4500 PSI AT 28 DAYS CONCRETE.
2. REINFORCING BARS SHALL CONFORM TO ASTM A-615 GRADE 60 STEEL.
3. EARTH COVER: 2'-0" MINIMUM UP TO 5'-0" MAXIMUM. SIZE PAD ACCORDING TO AMOUNT OF EARTH COVER.
4. TOP OF BAFFLE TO MATCH TOP OF INFLUENT PIPE.
5. REMOVE CONCRETE PLUGS FROM TOP OF STRUCTURE PRIOR TO INSTALLING GRADE RINGS AND MANHOLE CASTINGS.
6. INFLUENT INVERT SHALL BE 4-INCHES HIGHER THAN EFFLUENT INVERT.
7. TANKS LONGER THAN 126" MAY REQUIRE A THIRD OPENING OVER THE BAFFLE.