



STANDARD DRIVEWAY CULVERT

Created: November 5, 2020

Revised: July 18, 2023

Scale: N.T.S.

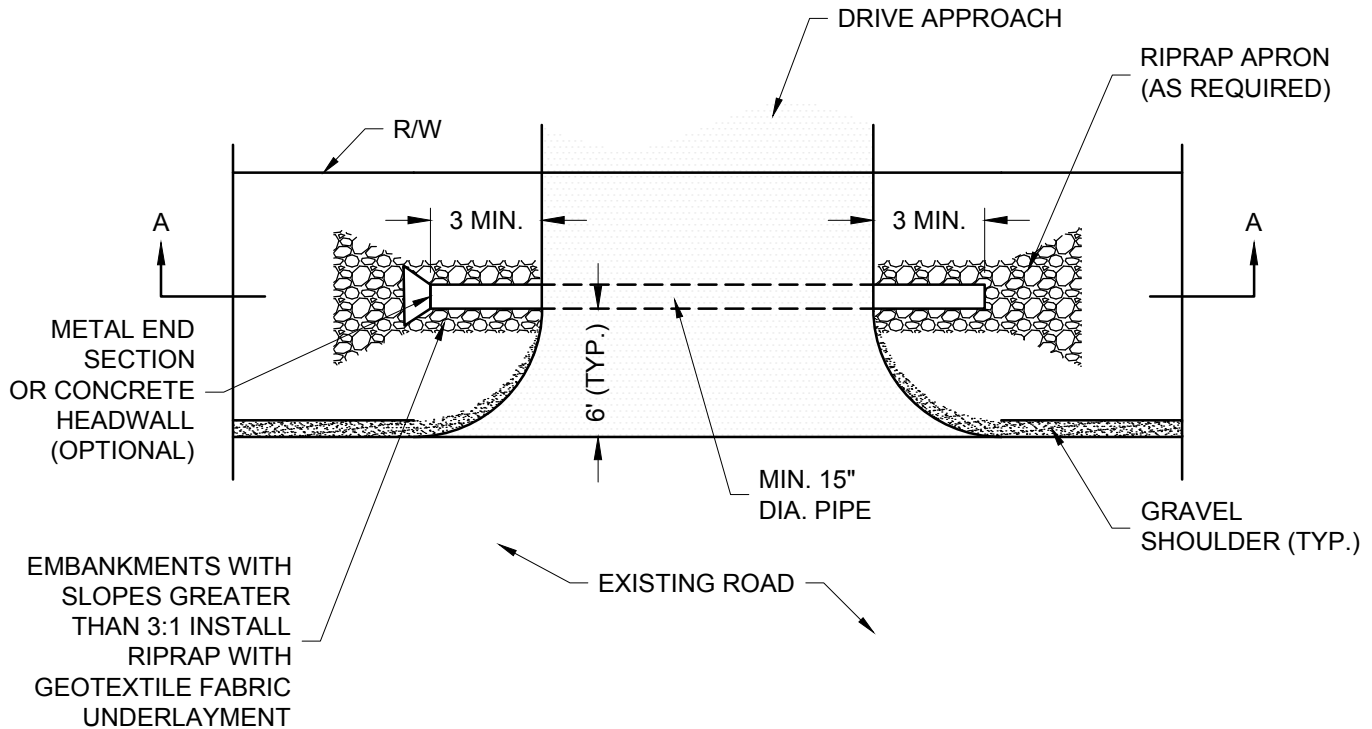

SECTION A-A

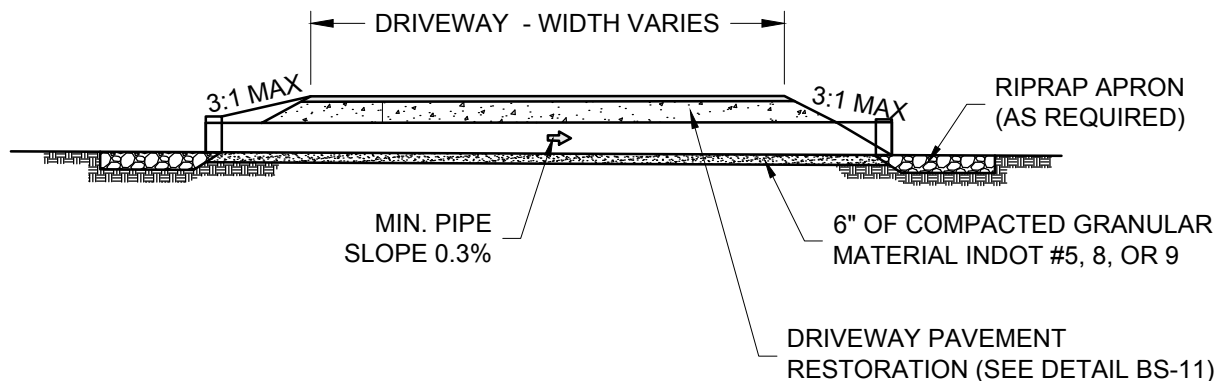

NOTES:

1. REFER TO MANUFACTURERS SPECIFICATIONS FOR DEPTH OF COVER REQUIREMENTS FOR CULVERT.